

DA Power Hook™













Instructions For Use

Table of Contents





1. Important Notices	1
1.1 Warning and Safety notices	1
1.2 Symbols and Definitions	3
1.3 Information of the Manufacturer	4
2. Introduction	5
2.1 Intended Use	5
2.2 Intended User	5
2.3 Patient Profile	6
2.4 Operation Ambient	5
2.5 Shipping and Storage	6
2.6 Product Lifetime	6
3. Electrical Technical Information and Operating Methods	7
3.1 Specifications	7
3.2 Parts List	7
3.3 Operating Methods	9
4. Maintenance, Cleaning and Sterilization	25
4.1 Maintenance	25
4.2 Power Hook Elevator Assembly; Power Supply Assembly; Foot Pedal Assembly; Side Rail Clamp, ACT-015, US	25
4.3 Connector Set; Extension Bar; Mobile Handle; Femoral Hook, 110°, Left; Femoral Hook, 110°, Right; Femoral Hook, 90°, Left; Femoral Hook, 90°, Right	26
5. Troubleshooting	27
6. Disposal of Waste	28
7. Appendix	29
7.1 Electromagnetic Emissions	29
7.2 Electromagnetic Immunity	30
7.3 Recommended Separation Distances	34

1. Important Notices

1.1 Warning and Safety notices





-  To ensure safe operation of the equipment, please read these instructions completely and keep this manual accessible for future reference.
-  Do not use accessories which are not supplied or recommended by the manufacturer. Other accessories may adversely affect EMC performance.
-  Household electronic devices such as humidifiers, heaters or microwaves, and so on may be susceptible to cause interference with the device.
-  Do not expose the device to strong electrostatic fields or strong magnetic fields to avoid inaccurate results.
-  If the device exhibits abnormal behavior due to electromagnetic disturbances, please relocate the device accordingly.
-  Use of this device adjacent to or stacked with other devices should be avoided as it could result in improper operation.
-  The United DA Power Hook should be kept at least 30 cm (12 inches) away from the wireless communication devices, such as networking devices, mobile phones, and walkie-talkies, to prevent potential performance degradation.
-  Caution: This equipment is not intended for use in residential environments and may not adequately protect radio reception in such environments.
-  The nominal voltage range is AC 100-240V. Please confirm the electrical environment in the operation room is appropriate.
-  The United DA Power Hook is installed on the rail of the operating table. Please confirm that the table rail can support more than 50.7 pounds (23kg).
-  Use of the United DA Power Hook with patients weighing more than 297.6 pounds (135 kg) could result in damage to the Hook, potential injury to the patient, or harm to the healthcare professionals.

1. Important Notices

-  Before and after each use, inspect the components, and accessories for possible damage, excessive wear, or non-functioning parts. Carefully inspect all critical accessible areas, joints, and all moving parts for potential damage or non-function. Do not use or process damaged or defective parts. Contact United Orthopedic Corporation for repair or replacement.
-  Please adhere to the duty cycle: 10%, with a maximum of 2 minutes ON followed by 18 minutes OFF.
-  No modifications of the United DA Power Hook or its components are allowed. Any modification to the equipment may result in damage, potential injury to the patient, or harm to the healthcare professionals.
-  If high-frequency surgical equipment, cardiac defibrillators, or cardiac defibrillator monitors are to be used with the United DA Power Hook, please refer to the manufacturer's instructions of those devices.
-  Do not use equipment in the presence of flammable anesthetics, gases, disinfecting agents, cleaning solutions, or any material susceptible to ignition due to electrical sparking.

1. Important Notices

1.2 Symbols and Definitions

Symbol	Title of symbol	Description of symbol	Standard/Ref. No.
	Catalogue number	Indicate the manufacturer's catalogue number.	ISO 15223-1 / 5.1.6
	Manufacturer	Indicate the medical device manufacturer, as defined in EU Directives 93/42/EEC and EU Regulation 2017/745.	ISO 15223-1 / 5.1.1
	Caution	Indicate the need for the user to consult the instructions for use for important cautionary information such as warnings and precautions that cannot, for a variety of reasons, be presented on the medical device itself.	ISO 15223-1 / 5.4.4
	Applied part TYPE B	This is an applied part TYPE B in accordance with IEC 60601-1 and is generally suitable for applications involving external or internal contact with the patient, excluding the heart. The patient circuit is connected to protective earth and this equipment should be connected only to hospital grade AC outlets with a protective earth ground.	IEC 60417 / 5840
	Refer to manual	Refer to instruction manual/booklet.	ISO 7010 / M002
IPX6	IPX6	According to IEC60529, the product can operate normally after being subjected to powerful water jets.	IEC 60529

1. Important Notices

1.3 Information of the Manufacturer



United Orthopedic Corporation
 No. 57, Park Ave. 2, Science Park
 Hsinchu, Taiwan
 TEL: +886-3-5773351
 FAX: +886-3-5777156
 E-MAIL: service@unitedorthopedic.com

2. Introduction

2.1 Intended Use

The United DA Power Hook is intended for support and lift the patient's femur during direct anterior approach total hip arthroplasty, controlled by a foot pedal. It facilitates the surgeon's operation and improve the accuracy of implant placement.

2.2 Intended User

The intended users to apply this device and the relevant procedures are certified surgeons and professional nursing staff. Users are expected to possess basic medical knowledge and significant experience in general surgical procedure. There are no limitations regarding the user's gender and age. Before using the United DA Power Hook, users must read this Instructions For Use.

2.3 Patient Profile

The patient's weight should not exceed 297.6 pounds/135 kg, restricted by the maximum load capacity of United DA power hook (33.1 pounds/15 kg) for lifting a single thigh weight*.

*Basing on the definition of human body mass distribution in IEC60601-1, the weight of the single side thigh is approximately 11.1% of full body weight.

2.4 Operation Ambient

The United DA Power Hook is used in the operating room.

Ambient temperature : 20°C

Relative humidity : 20%~60%

Atmospheric pressure : 86kpa~106kpa

2. Introduction

2.5 Shipping and Storage

During shipment, the United DA Power Hook should be kept in an environment with the following limits:

Ambient temperature : -20°C~70°C

Relative humidity : 0%~93%

Atmospheric pressure : 86kpa~106kpa

When not in use, all components should be stored with care to prevent damage.

They should be stored in a clean, dry environment. Keep stored instruments on carts or shelving in a storage area free from dust, insects, chemical vapors, and extreme changes in temperature and humidity.

2.6 Product Lifetime

The United DA Power Hook includes both electronic and non-electronic components. The product's service lifetime is defined as 5 years. At the time of delivery, your product complies with existing regulations and standards. However, despite proper use, routine inspection, prescribed service, maintenance, and repairs, the product is subject to aging and wear.

Therefore, United Orthopedic Corporation cannot guarantee the product's safety for more than 5 years after the date of manufacture and recommends that the product be taken out of service. For maintenance information, please see Section 4.

3. Electrical Technical Information and Operating Methods

3.1 Specifications

Name : United DA Power Hook
 Input Voltage : AC 100-240V
 Duty Cycle : 10%, Max. 2 min ON/18 min OFF
 Stroke : 150mm
 Average Speed : 4.5mm/s
 Max. Load : 33.1 pounds (15kg)
 Plug Support : US
 Type B per IEC 60601-1

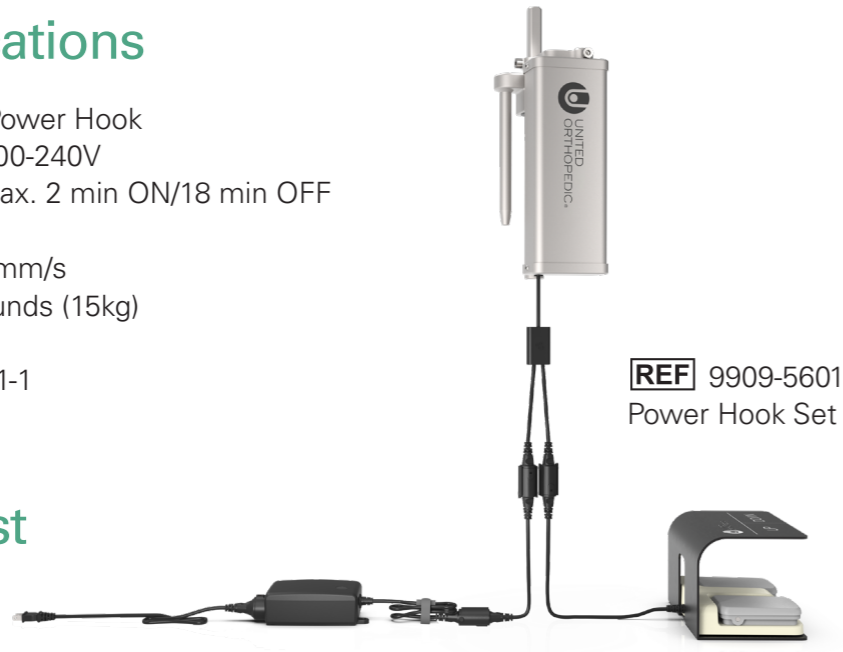

REF 9909-5601
Power Hook Set

3.2 Parts List

Description	
	<p>Power Supply Assembly Manufacturer : TiMOTION Model No : TP9-1 Input : AC 100-240V, 50/60Hz, 145VA Output Voltage Current : DC 29V, 2.5A Connector : AC-US Plug,DC-DIN 5P Female Cable Length(mm) : AC-2000, DC-500+extension 1500</p>
<p>Power Hook Elevator Assembly Voltage : DC 24V Max. Current : Max. 3.2Amp Connector : Y cable Cable Length(mm) : L1=100, L2=100, L3=100</p>	<p>Foot Pedal Assembly Voltage : DC 20~32V Connector : DIN 5P Male Cable Length(mm) : 1500 IP Rating : IPX6 Button Definition : Left key-Extend, Right key-Retract</p>

3. Electrical Technical Information and Operating Methods

Description	
	<p>REF 9909-5609 Side Rail Clamp, ACT-015, US</p>
	<p>REF 9909-5606 Connector Set</p>
	<p>REF 9909-5607 Extension Bar</p>
	<p>REF 9909-5603 Mobile Handle</p>
	<p>REF 9909-5710 Femoral Hook, 110°, Left</p>
	<p>REF 9909-5810 Femoral Hook, 110°, Right</p>
	<p>REF 9909-5709 Femoral Hook, 90°, Left</p>
	<p>REF 9909-5809 Femoral Hook, 90°, Right</p>

3. Electrical Technical Information and Operating Methods

3.3 Operating Methods

Before Surgery STEP 1. Side Rail Clamp, ACT-015, US Assembly

Select the left or right side rail that corresponds to the operational side. Align the **Side Rail Clamp, ACT-015, US** with the notches on the table rail (this feature is only available for US specification rails). To avoid possible interference during assembly, ensure that the **Side Rail Clamp, ACT-015, US** is loosened in advance. Hang the **Side Rail Clamp, ACT-015, US** onto the rail and slide it to the appropriate location.



⚠ The **Side Rail Clamp, ACT-015, US** can only be installed on the seat rail of the operating table. Do not install it on the foot rail of the operating table.

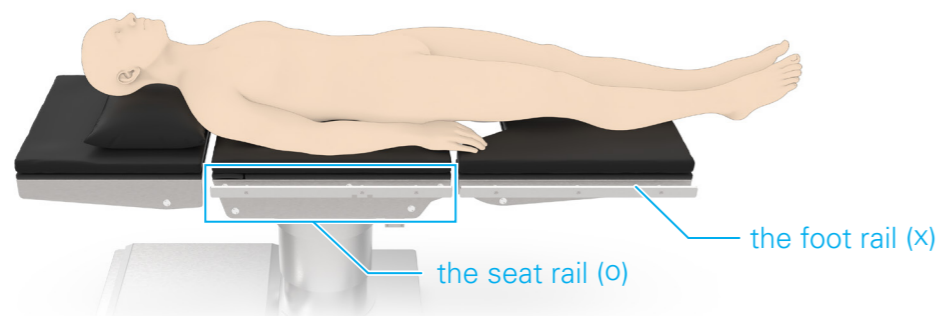

⚠ Do not over fasten the **Side Rail Clamp, ACT-015, US** before the **Power hook elevator assembly** is set to avoid clamp deformation.

⚠ Appropriate Location : The round hole of the **Side Rail Clamp, ACT-015, US** should be positioned on the right side.

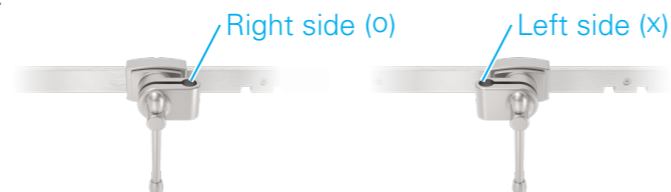

3. Electrical Technical Information and Operating Methods

Before Surgery STEP 2. Set up Power Hook Elevator Assembly

This operation should be performed by two people. Insert the assembly rod of the **Power Hook Elevator Assembly** into the round hole of the **Side Rail Clamp, ACT-015, US** and adjust the **Power Hook Elevator Assembly** to the appropriate height. Fasten the **Side Rail Clamp, ACT-015, US** to lock the **Power Hook Elevator Assembly** in place.



⚠ This operation should be performed by two people for safety concern. It is recommended that one person holds and controls the **Power Hook Elevator Assembly**; the other person holds and loosens the **Side Rail Clamp, ACT-015, US**.

⚠ Appropriate Location:
The round hole surface of the **Side Rail Clamp, ACT-015, US** is aligned parallel to the table rail.

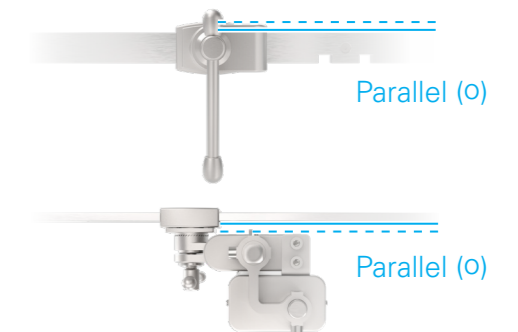

From a top view, the **Power Hook Elevator Assembly** should be parallel to the table rail.

The clamping position must be no lower than the midpoint of the assembly rod on the **Power Hook Elevator Assembly**.

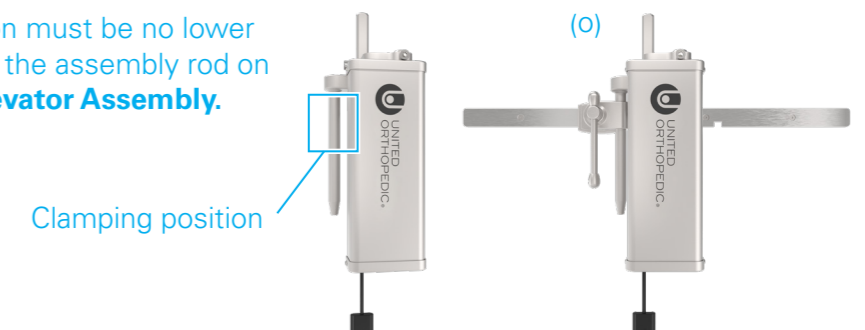

3. Electrical Technical Information and Operating Methods

Before Surgery STEP 3. Power Supply Assembly and Foot Pedal Assembly Connection

Place the **Power Supply Assembly** and **Foot Pedal Assembly** in an appropriate locations on the floor. Connect the wires among the **Power Supply Assembly**, **Foot Pedal Assembly**, and **Power Hook Elevator Assembly**. Finally, plug the power supply into the outlet provided in the operating room.

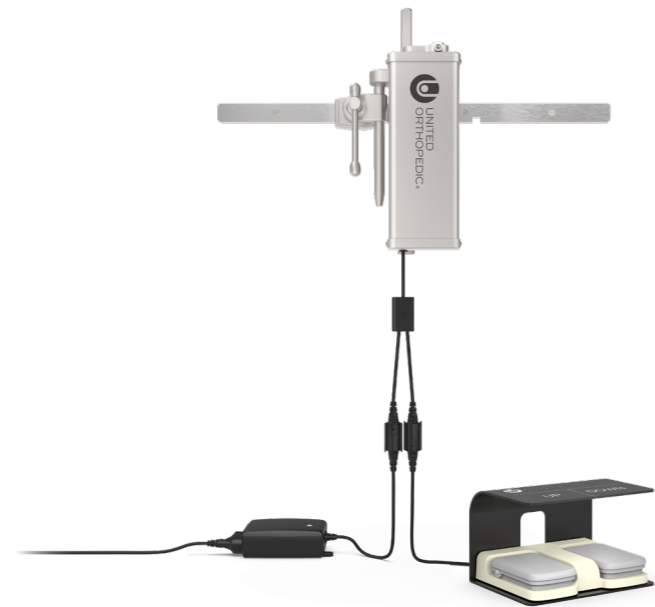

- ⚠ The nominal voltage range is AC 100-240V. Please confirm the electrical environment of operation room meets this requirement.
- ⚠ Use the cable ties provided with the **Power Supply Assembly** and **Foot Pedal Assembly** to secure excess wire, reducing the risk of tripping.
- ⚠ The wire connectors are designed to be foolproof. To connect, first open the cover of the female connector, then align the male connector with the guide feature and press it straight in. Finally, snap the cover of the female connector closed.

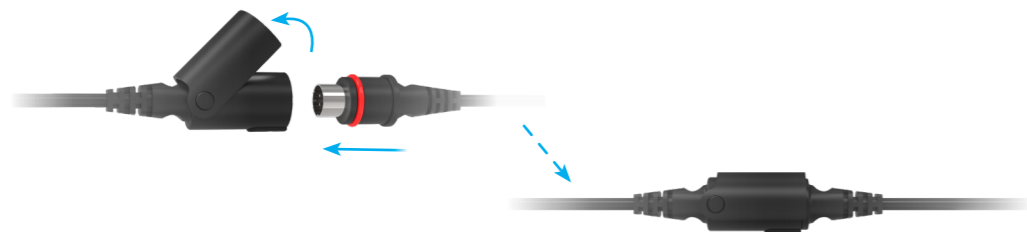

3. Electrical Technical Information and Operating Methods

Before Surgery STEP 4. Control confirmation

Press the "UP" and "DOWN" pedal to confirm normal operation. Then, press the "DOWN" pedal to return the **Power Hook Elevator Assembly** to the lowest point. Verify that the fixation position of the **Power Hook Elevator Assembly** is appropriate. If further adjustment is needed, it needs to be performed by two people for safety. Slightly loosen the **Side Rail Clamp, ACT-015, US** and reposition both the clamp and the **Power Hook Elevator Assembly** to an appropriate position. Re-fasten the **Side Rail Clamp, ACT-015, US** to secure it in place.

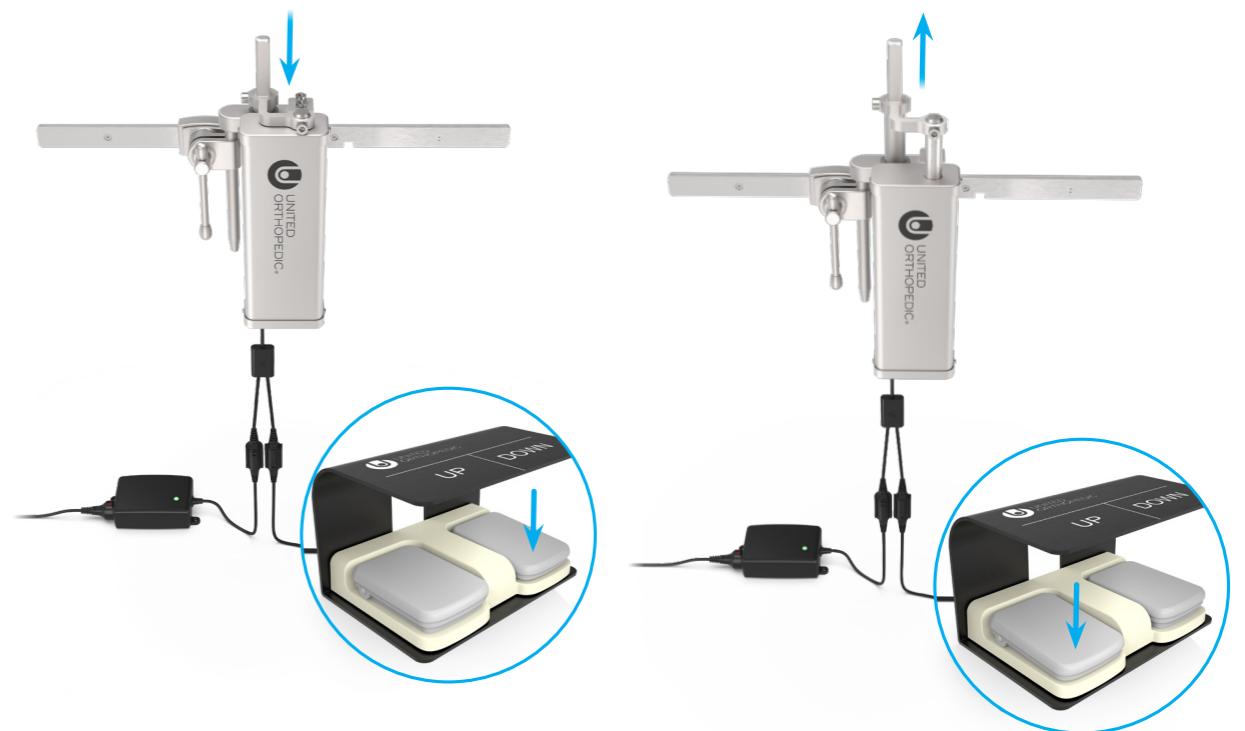

- ⚠ For safety, any additional adjustments should always be performed by two people.
- ⚠ The foot pedals are located beneath the protective cover. Please step correctly on the foot pedal (light gray) to control the elevation or declination of the device. Stepping on the incorrect area (e.g., the protective cover) may result in deformation or damage to the **Foot Pedal Assembly**.

3. Electrical Technical Information and Operating Methods

Before Surgery STEP 5. Preparation for Sterilization Barrier

Cover the **Power Hook Elevator Assembly** with two sterile drapes. Ensure that the entire assembly is fully covered by the sterile drapes throughout the full range of motion controlled by the **Foot Pedal Assembly**.

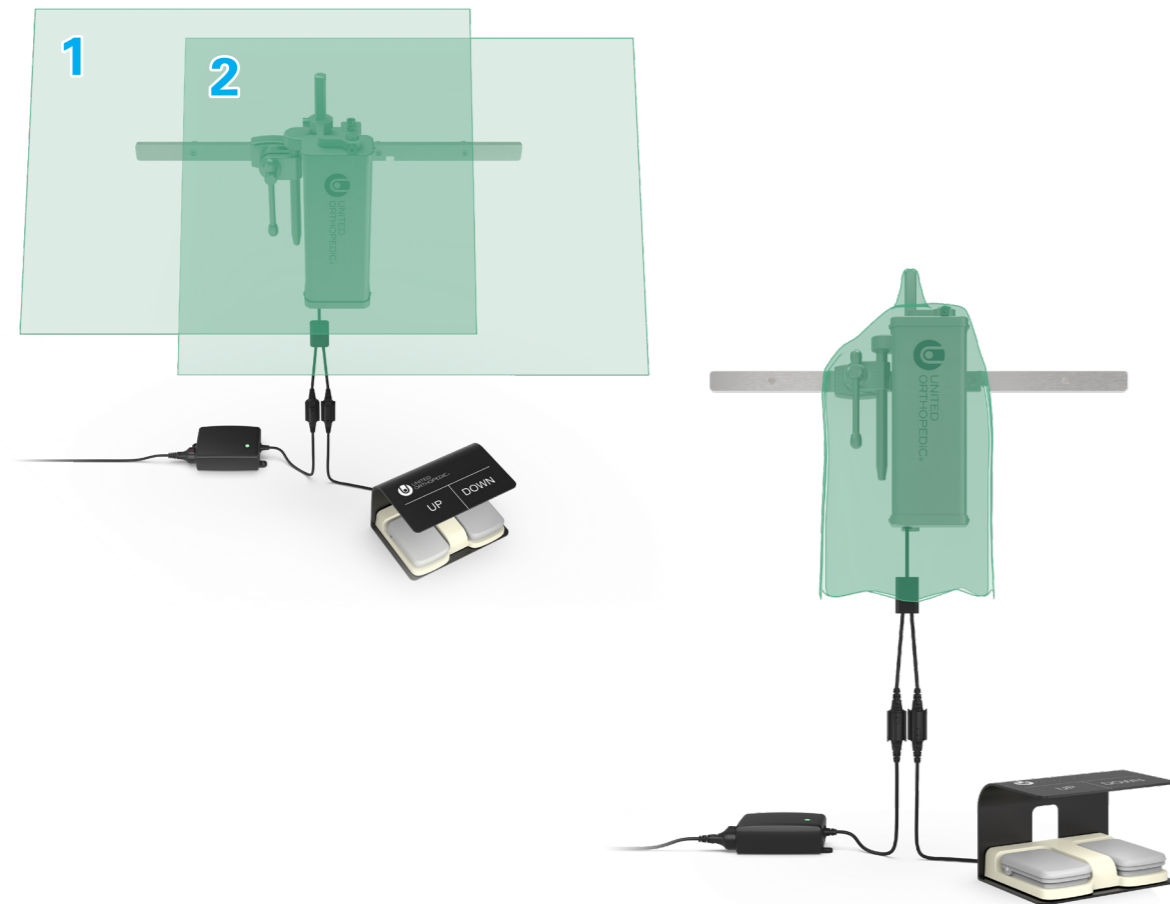

⚠ The **Power Hook Elevator Assembly**, the **Side Rail Clamp, ACT-015, US**, the **Foot Pedal Assembly**, and the **Power Supply Assembly** do not come into contact with the patient. Make sure they are covered by sterile drapes.

⚠ We do not provide the sterile drape; this step is a recommended method for setting up the sterile area. Hospitals may adjust the setup as needed, using qualified sterile drapes according to specific requirements.

3. Electrical Technical Information and Operating Methods

During Surgery STEP 6. Connector Set Assembly

Place the **Connector Set** onto the post of the **Power Hook Elevator Assembly** over the covered sterile drapes. Press down to avoid loosening.

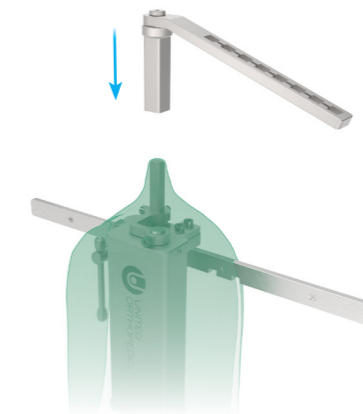

Accessory Installation Use of Extension Bar

If additional height is needed (e.g. for larger patients) after setting up the **Power Hook Elevator Assembly**, the **Extension Bar** can be applied. Insert the **Extension Bar** onto the post of the **Power Hook Elevator Assembly**, then place the **Connector Set** onto the **Extension Bar**.



⚠ Because the **Connector Set** can rotate, be careful when assembling it to avoid injury.

⚠ After completing the assembly, test the device to ensure there's no interference during operation.

3. Electrical Technical Information and Operating Methods

During Surgery STEP 7. Orientation of Connector Set

Confirm the mobility of the **Connector Set**. Ensure that the **Connector Set** is oriented toward the distal direction (foot end).

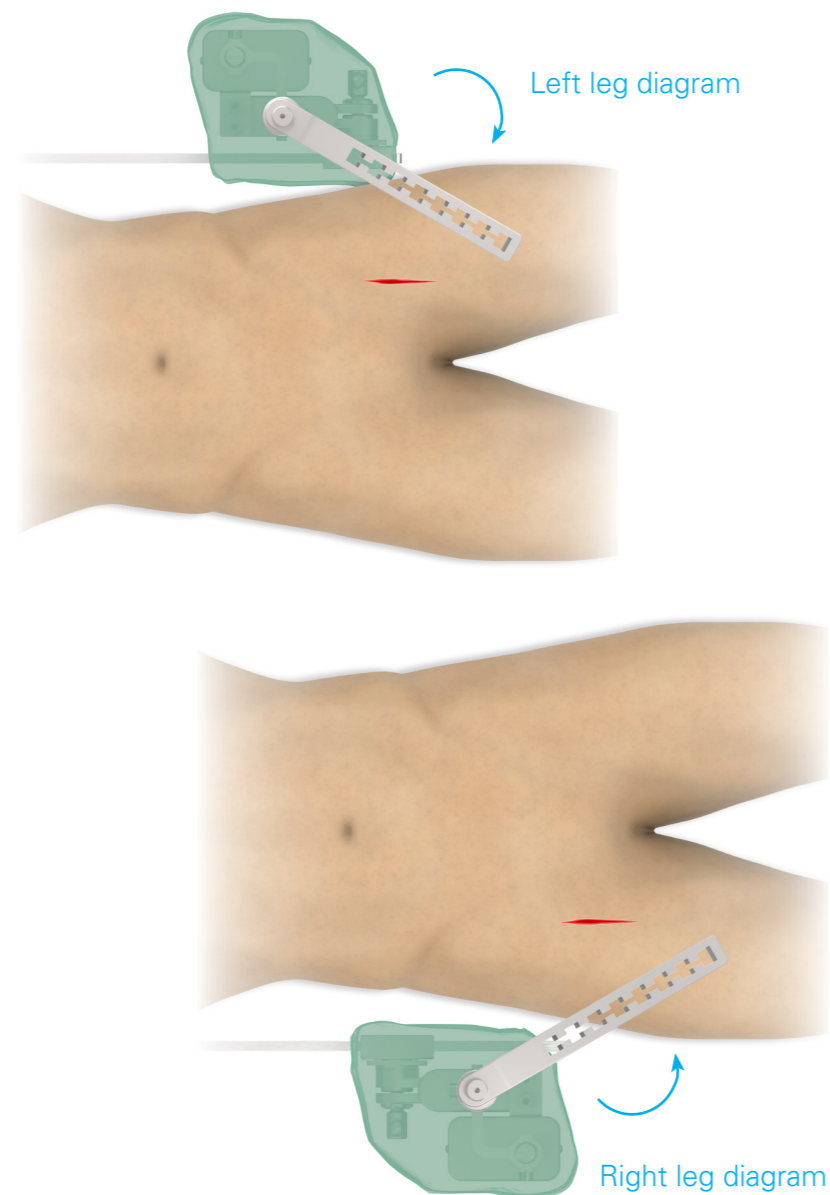

3. Electrical Technical Information and Operating Methods

During Surgery STEP 8. Assembly of the Femoral Hook

Select the appropriate type of **Femoral Hook**. Press the sleeve on the **Mobile Handle**, align the planar features of the **Mobile Handle** with those of the **Femoral Hook**, attach the **Femoral Hook**, and release the sleeve to complete the assembly.

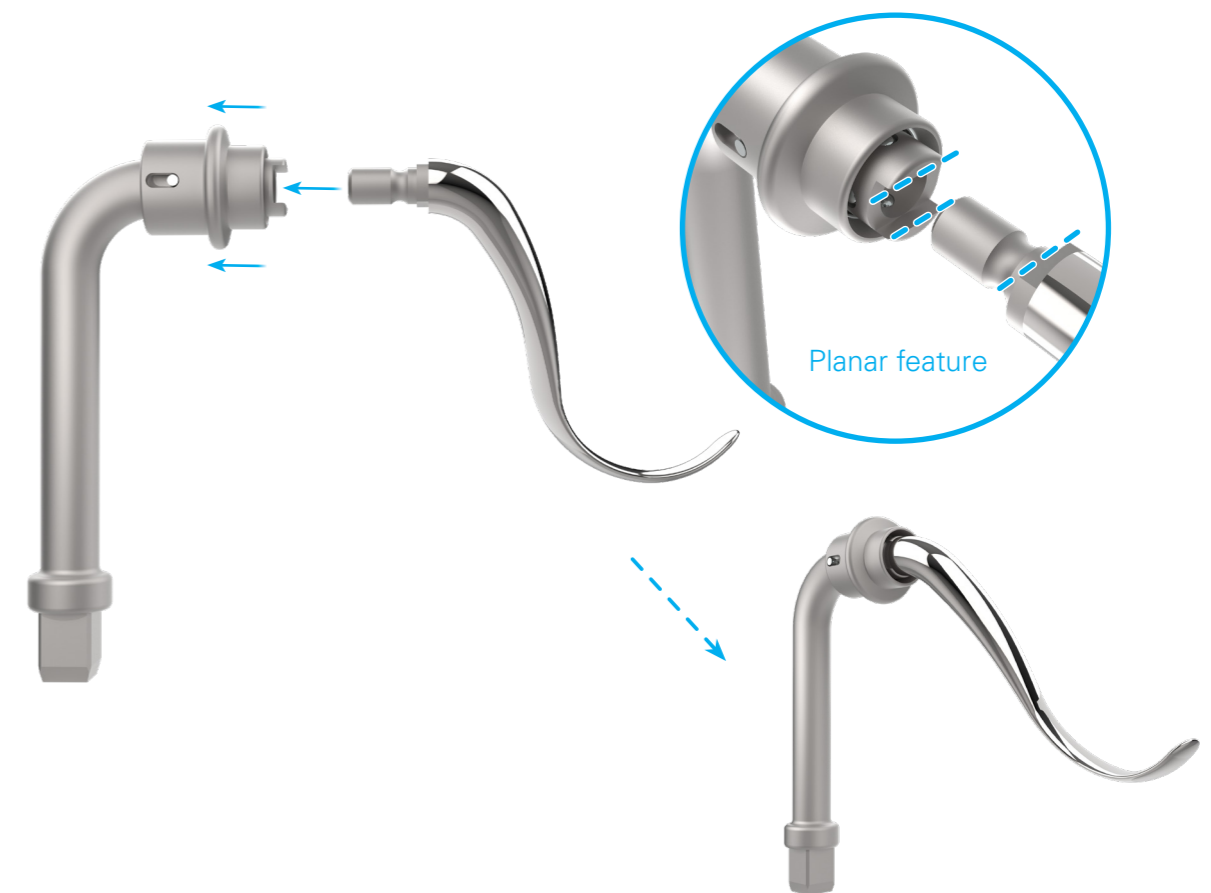

We provide four types of Femoral Hooks:

- Femoral Hook, 110°, Left
- Femoral Hook, 110°, Right
- Femoral Hook, 90°, Left
- Femoral Hook, 90°, Right



3. Electrical Technical Information and Operating Methods

During Surgery STEP 9. Hook at Proximal Femur

Hold the post of the **Mobile Handle** and hold the **Femoral Hook** to support beneath the patient's proximal femur.

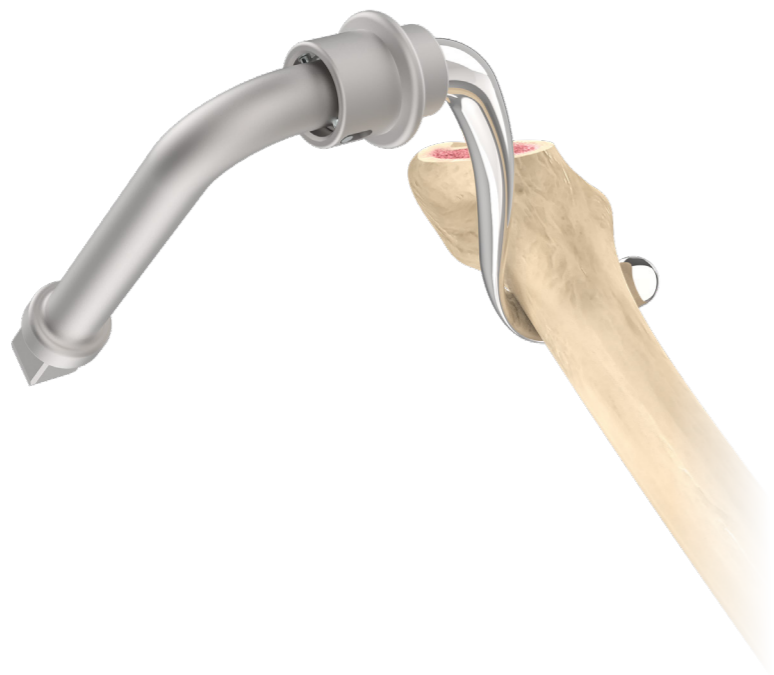

3. Electrical Technical Information and Operating Methods

During Surgery STEP 10. Set the Femoral Hook

After confirming that the **Femoral Hook** is appropriately positioned, insert the base of **Mobile Handle** into the appropriate hole on the **Connector Set**. If the height of the **Connector Set** is insufficient, elevate the **Connector Set** to an ideal height using the **Foot Pedal Assembly** before engaging the **Mobile Handle** to the **Connector Set**.

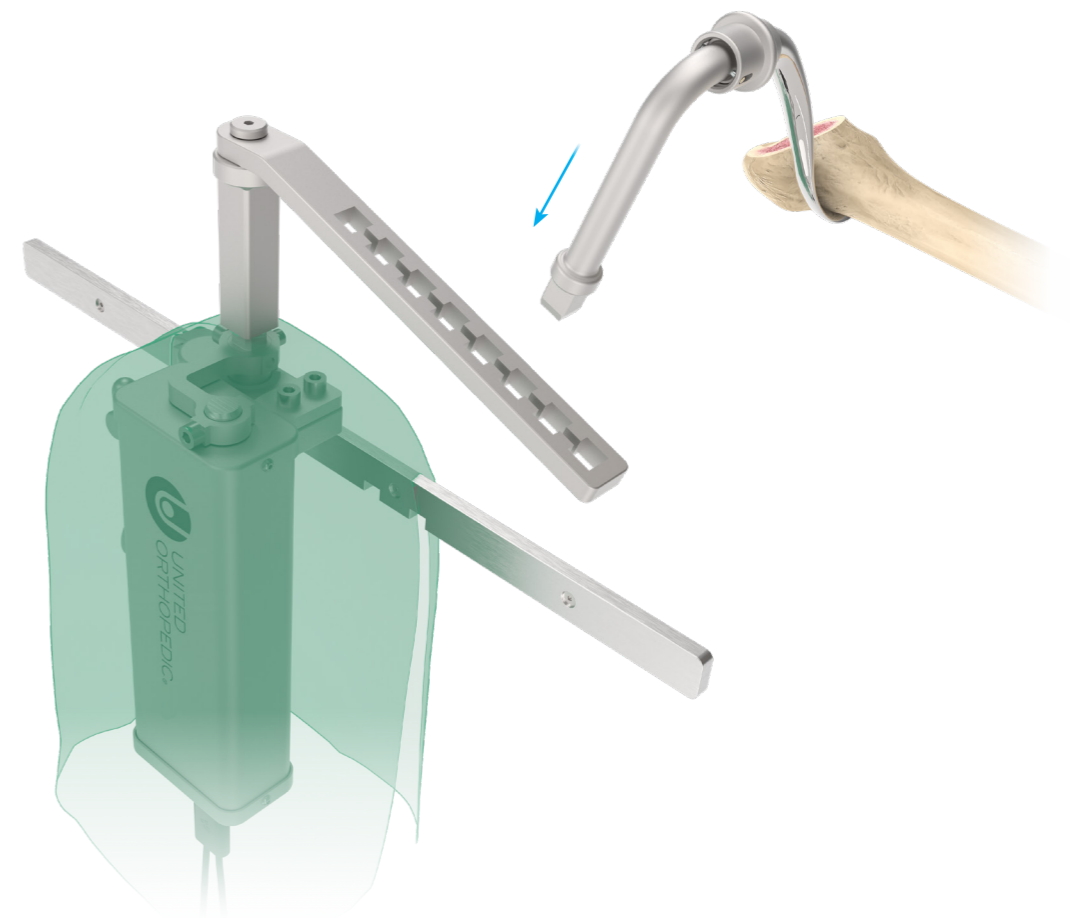

⚠ If the required elevation exceeds 10 cm before starting the assembly procedure, it is recommended that users utilize the **Extension Bar** to add additional height, as the device itself provides a maximum elevation stroke of 15 cm.

3. Electrical Technical Information and Operating Methods

During Surgery STEP 11. Control of United DA Power Hook

Press the "UP" foot pedal to elevate and the "DOWN" foot pedal to lower the assembly if necessary. During this operation, users must monitor tension on the **Femoral Hook** carefully to avoid any potential complication. Release the pedal to stop the **Femoral Hook** immediately at its current height.

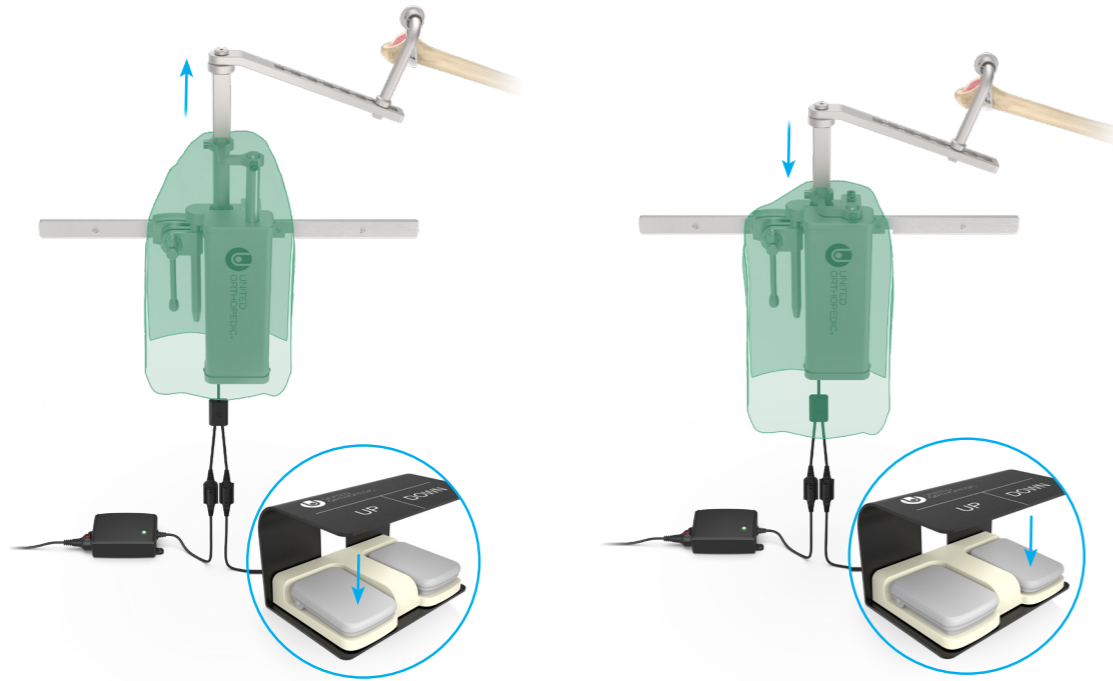

- ⚠ Please adhere to the duty cycle: 10%, with a maximum of 2 minutes ON followed by 18 minutes OFF.
- ⚠ After adjusting the **Power Hook Elevator Assembly** to the appropriate height, the user should move their foot away from the **Foot Pedal Assembly** to prevent accidentally pressing the pedal.
- ⚠ The foot pedals are located beneath the protective cover. Please step correctly on the foot pedal (light gray) to control the elevation or declination of the device. Stepping on the incorrect area (e.g., the protective cover) may result in deformation or damage to the **Foot Pedal Assembly**.
- ⚠ Do not attempt to over-force the femur upward with excessive tension.

3. Electrical Technical Information and Operating Methods

During Surgery STEP 12. Removal of the Femoral Hook

Before removing the **Femoral Hook**, the hook should be returned to the lowest point (or an appropriate height to avoid interference) by controlling the **Foot Pedal Assembly**. Next, remove the **Mobile Handle** and the **Femoral Hook** from the **Connector Set**, and then retrieve the **Femoral Hook** from the patient's proximal femur. Press the sleeve of the **Mobile Handle** and pull out the **Femoral Hook** to separate the two components.

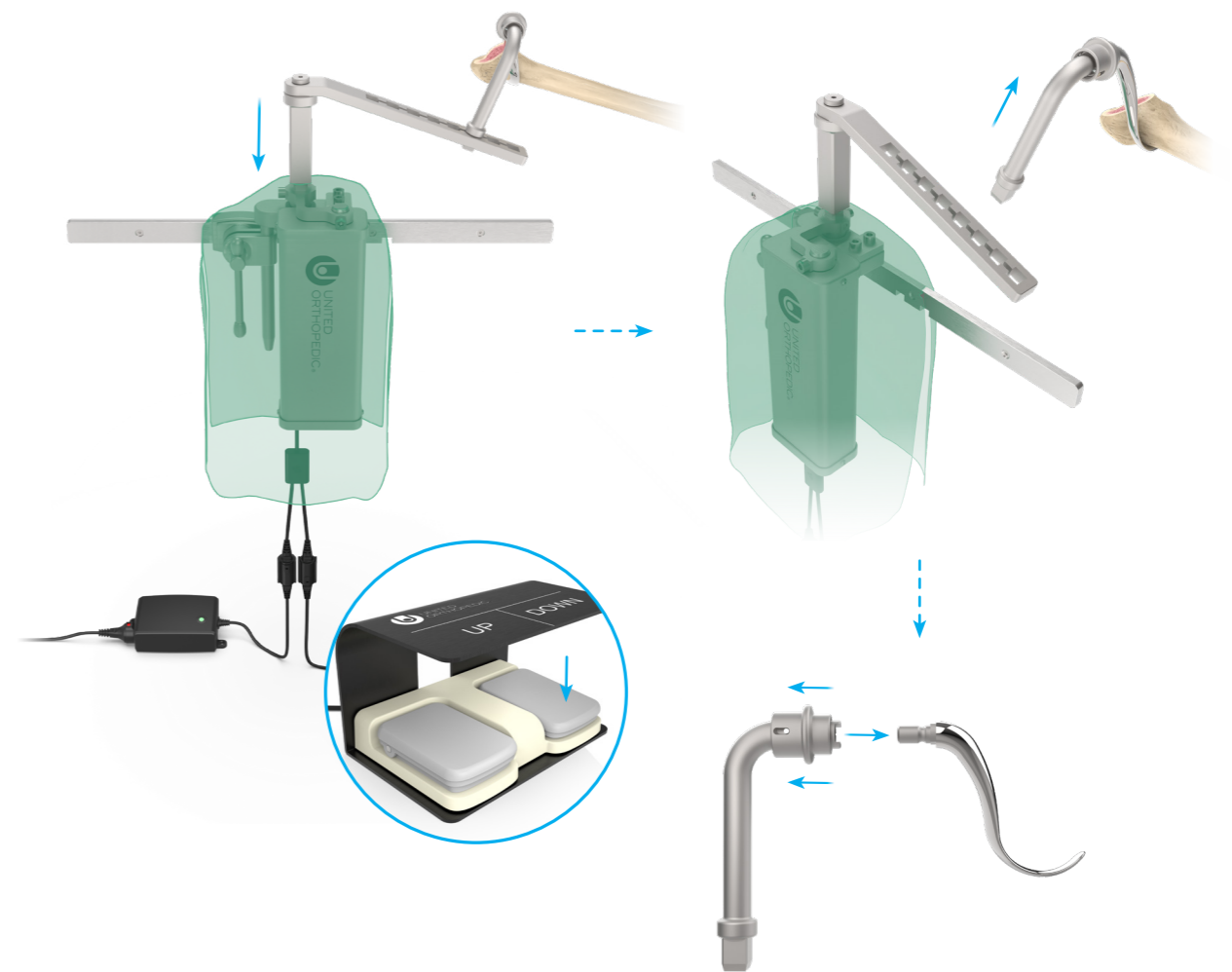

- ⚠ Forced removal of the **Femoral Hook** is prohibited and can be harmful when the **Femoral Hook** is loaded for proximal femur elevation.

3. Electrical Technical Information and Operating Methods

After Surgery STEP 13. Removal of Connector Set

Remove the **Connector Set** and the sterile drapes.

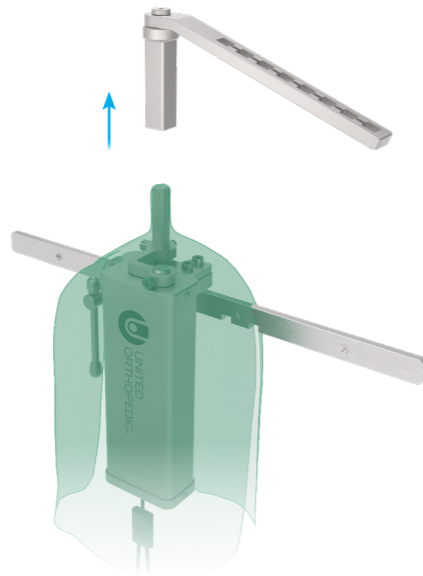

Accessory Remove Removal of Extension Bar

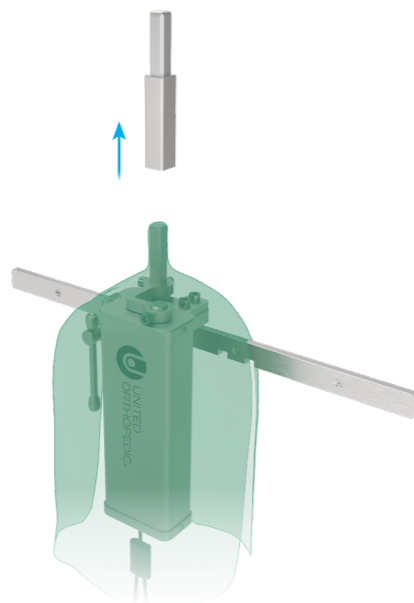

3. Electrical Technical Information and Operating Methods

After Surgery STEP 14. Removal of Power Supply Assembly and Foot Pedal Assembly

Confirm that the **Power Hook Elevator Assembly** has been returned to the lowest point. Unplug the power and disconnect the wires connecting the **Power Hook Elevator Assembly**, the **Power Supply Assembly**, and the **Foot Pedal Assembly**.

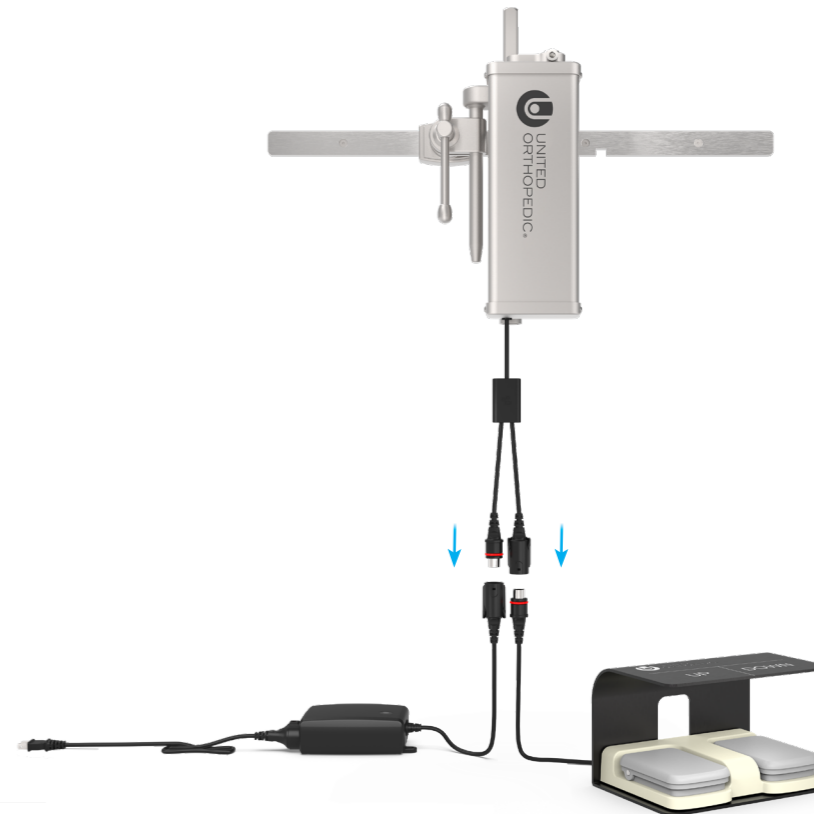

! When disconnecting the wire connectors, open the cover of the female connector, pull out the male connector, and then close the cover of the female connector for safe storage.

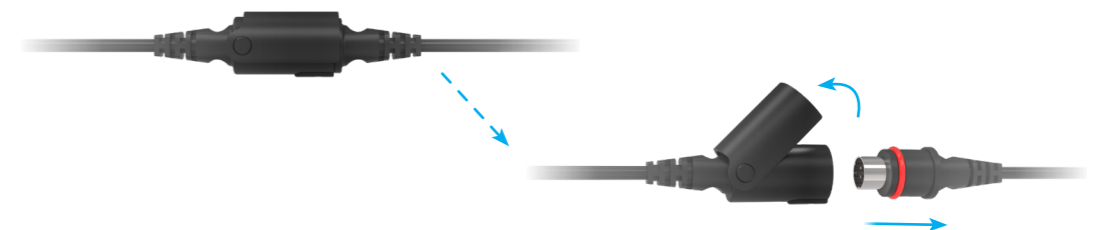

3. Electrical Technical Information and Operating Methods

After Surgery STEP 15. Removal of Power Hook Elevator Assembly

This operation should be performed by two people. Hold the **Power Hook Elevator Assembly** before loosening the **Side Rail Clamp, ACT-015, US**. After loosening, carefully extract the **Power Hook Elevator Assembly** from the **Side Rail Clamp, ACT-015, US**.



⚠ This operation should be performed by two people for safety concern. It is recommended that one person holds and controls the **Power Hook Elevator Assembly**; the other person holds and loosens the **Side Rail Clamp, ACT-015, US**.

3. Electrical Technical Information and Operating Methods

After Surgery STEP 16. Remove the Side Rail Clamp, ACT-015, US

Slide the **Side Rail Clamp, ACT-015, US** in loosened to the notch region of the table rail, and then remove it.

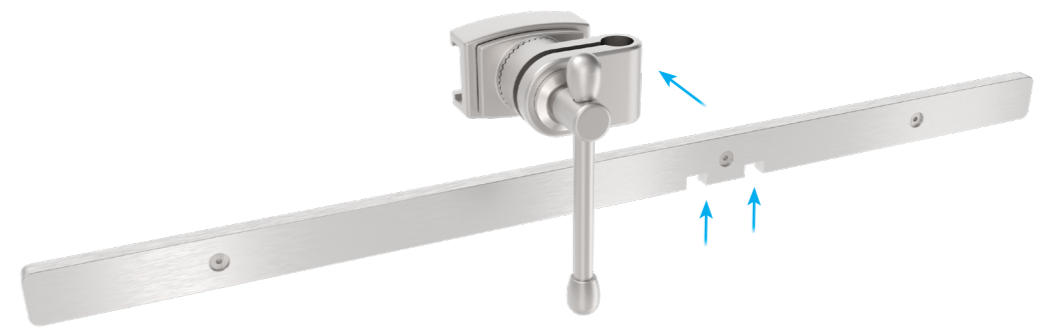

⚠ Do not secure the **Side Rail Clamp, ACT-015, US** when no assembly rod is inserted in the clamp hole. Inadequate fastening of this device may cause deformation of the clamp hole, which could affect future device assembly.

4. Maintenance, Cleaning and Sterilization

4.1 Maintenance

The United DA Power Hook consists of both non-sterilized and sterilized components, all of which are supplied non-sterile. Prior to each patient use, cleaning and sterilization of the sterilized components are required. The United DA Power Hook is reusable. Please refer to the United DA Power Hook Instructions for Use for correct operation, cleaning, and storage procedures.

4.2 Power Hook Elevator Assembly; Power Supply Assembly; Foot Pedal Assembly; Side Rail Clamp, ACT-015, US

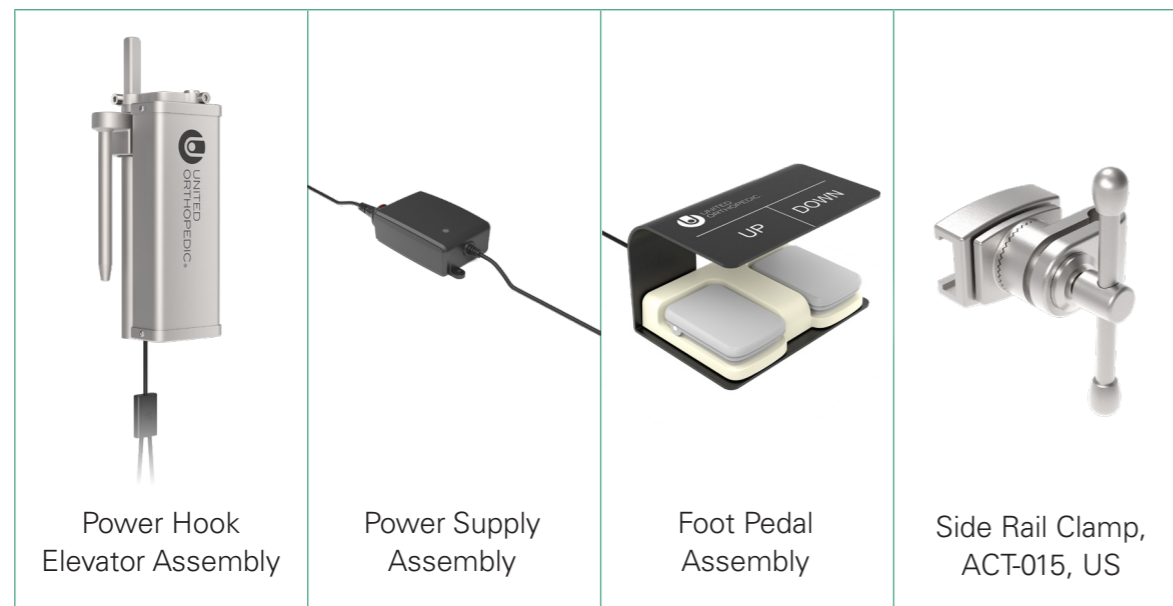

- These are the non-sterilized components.
- During use, ensure they are covered by sterile drapes.
- After use, refer to Section 3.3 to disassemble each component.
- Wipe the exterior surfaces clean with hospital-approved neutral cleaners, and then dry with a soft, lint-free cloth.

4. Maintenance, Cleaning and Sterilization

4.3 Connector Set; Extension Bar; Mobile Handle; Femoral Hook, 110°, Left; Femoral Hook, 110°, Right; Femoral Hook, 90°, Left; Femoral Hook, 90°, Right

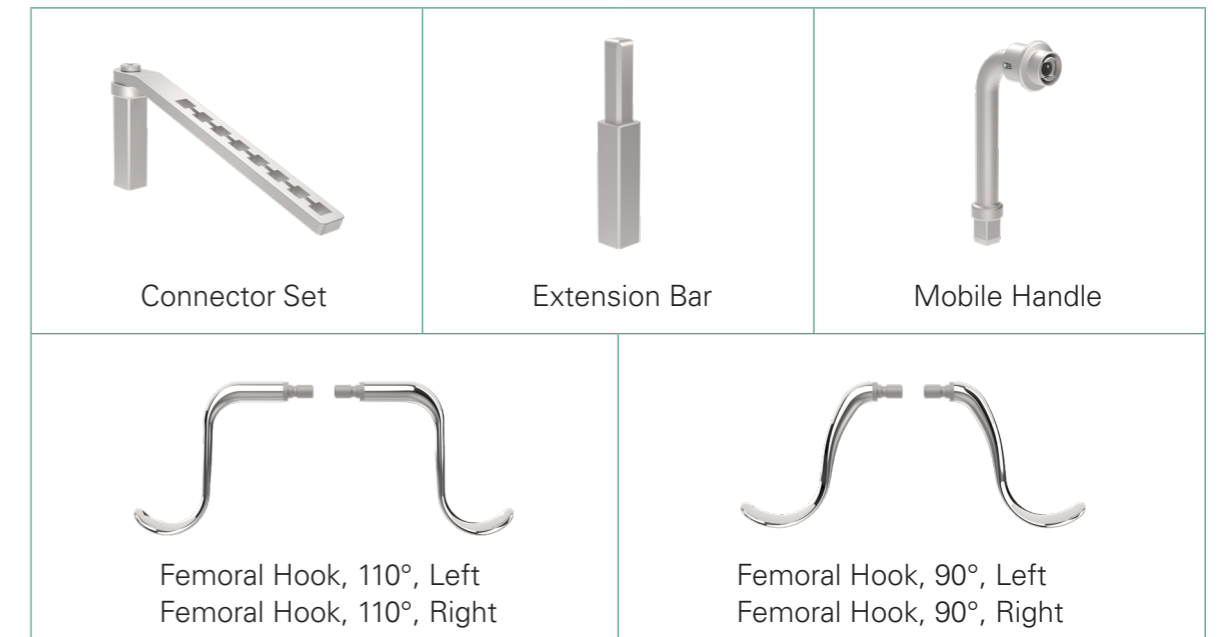

- These are the sterilized components.
- Prior to each patient use, these components should be inspected, cleaned, and sterilized.
- Sterilization of these components is achieved through steam. United Orthopedic Corporation recommends the following sterilization parameters:

Cycle Type	Pulse Number	Exposure Temperature	Minimum Exposure time	Minimum Drying times
Dynamic-Air-Removal (Pre-vacuum)	4	132°C (270°F)	4 minutes	30 minutes

- For detailed methods of cleaning, inspection, packaging, sterilization, and storage, please refer to UOC-UM-UN-00029 Reprocessing Instructions for Reusable Surgical Instruments available on the United Orthopedic Corporation website.

5. Troubleshooting

If power is lost during surgery while the **Femoral Hook** is engaged with the patient's femur and lifted, follow these steps:

1. Press the sleeve of the **Mobile Handle** to separate the **Femoral Hook** from the **Mobile Handle**.
2. Hold the **Femoral Hook** and lower it slowly.
3. Carefully pull out the **Femoral Hook** to detach it from the patient.

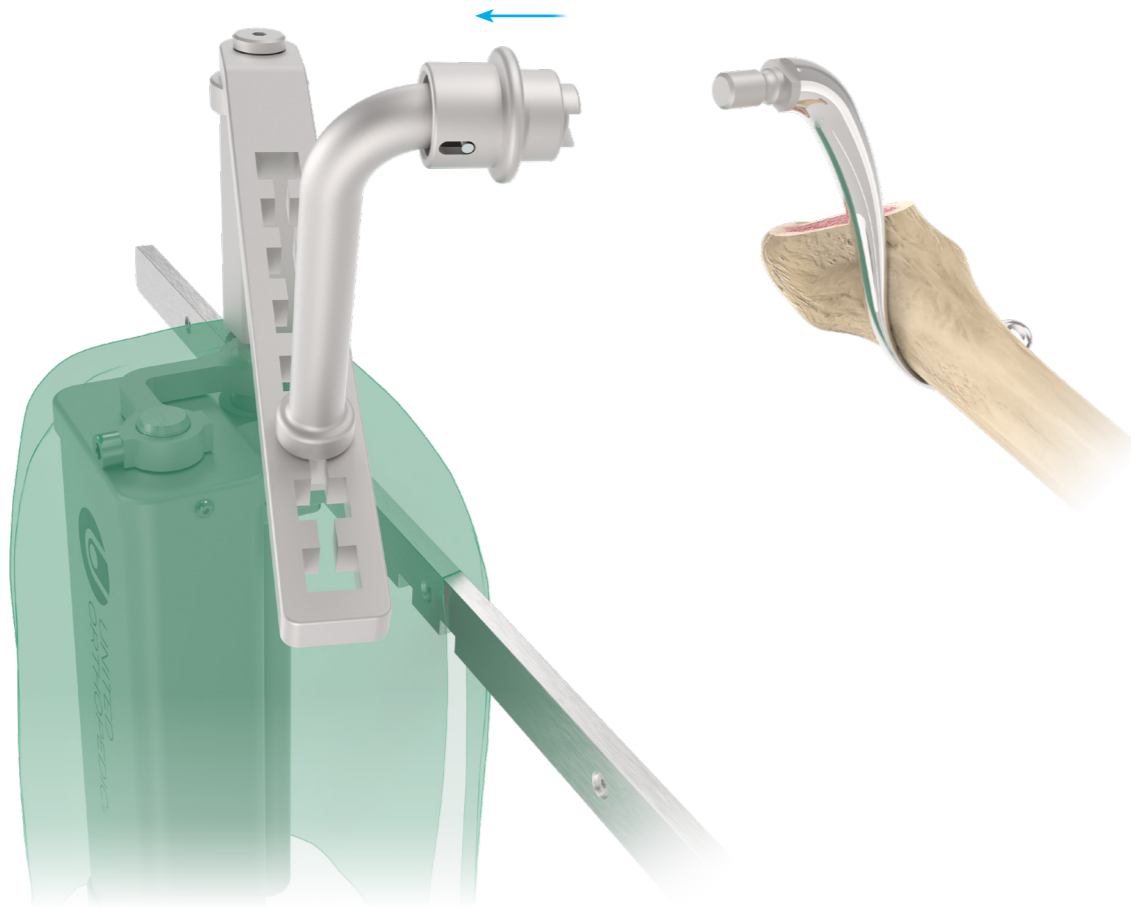

In the event of a temporary interruption of power (such as a DIP), the operation of the product may briefly stop, resulting in a loss of charging function. Once the interference is resolved, the system will automatically recover without causing any harm to individuals.

6. Disposal of Waste

After use, an instrument may pose a potential biohazard, as it could be contaminated with blood, body fluids, bone, or other tissues. Handle and dispose of this product according to accepted medical practices and applicable local, state, and national laws and regulations. Any sharp objects should be disposed of immediately after use in a sharps container that complies with national regulations. Sharp objects must not be bent, broken, or re-sheathed prior to disposal.

7. Appendix

7.1 Electromagnetic Emissions

Manufacturer's declaration-electromagnetic emissions		
<p>The United DA Power Hook is intended for use in the electromagnetic environment (for professional healthcare) specified below. The customer or the user of the United DA Power Hook should assure that it is used in such an environment.</p>		
Emission test	Compliance	Electromagnetic environment-guidance (for professional healthcare environment)
RF emissions CISPR 11	Group 1	The United DA Power Hook uses RF energy only for its internal function. Therefore, its RF emissions are very low and are not likely to cause any interference in nearby electronic equipment.
RF emissions CISPR 11	Class A	The United DA Power Hook is suitable for use in all establishments other than domestic and those directly connected to the public low-voltage power supply network that supplies buildings used for domestic purposes.
Harmonic emissions IEC 61000-3-2	Not applicable	
Voltage fluctuations/flicker emissions IEC 61000-3-3	Not applicable	

7. Appendix

7.2 Electromagnetic Immunity

Manufacturer's declaration-electromagnetic immunity			
<p>The United DA Power Hook is intended for use in the electromagnetic environment (for professional healthcare) specified below. The customer or the user of the United DA Power Hook should assure that it is used in such an environment.</p>			
Immunity test	IEC 60601 test level	Compliance level	Electromagnetic environment-guidance (for professional healthcare environment)
Electrostatic discharge (ESD) IEC 61000-4-2	Contact: ± 8 kV Air: ±2 kV, ±4 kV, ±8 kV, ±15 kV	Contact: ± 8 kV Air: ±2 kV, ±4 kV, ±8 kV, ±15 kV	Floors should be wood, concrete or ceramic tile. If floors are covered with synthetic material, the relative humidity should be at least 30%
Electrical fast transient/burst IEC 61000-4-4	± 2kV for power supply lines ± 1kV for input/output lines	± 2kV for power supply lines Not applicable	Mains power quality should be that of a typical professional healthcare environment
Surge IEC 61000-4-5	± 0.5kV, ±1kV line(s) to line(s) ± 0.5kV, ±1kV, ±2kV line(s) to earth	± 0.5kV, ±1kV line(s) to line(s) ± 0.5kV, ±1kV, ± 2kV line(s) to earth	Mains power quality should be that of a typical professional healthcare environment.
Voltage Dips, short interruptions and voltage variations on power supply input lines IEC 61000-4-11	Voltage dips: 0 % U_T ; 0,5 cycle 0 % U_T ; 1 cycle 70 % U_T ; 25/30 cycles Voltage interruptions: 0 % U_T ; 250/300 cycle	Voltage dips: 0 % U_T ; 0,5 cycle 0 % U_T ; 1 cycle 70 % U_T ; 30 cycles Voltage interruptions: 0 % U_T ; 300 cycle	Mains power quality should be that of a typical professional healthcare environment. If the user of the United DA Power Hook requires continued operation during power mains interruptions, it is recommended that the United DA Power Hook be powered from an uninterruptible power supply or a battery.
Power frequency (50, 60 Hz) magnetic field IEC 61000-4-8	30 A/m 50 Hz or 60 Hz	30 A/m 60 Hz	The United DA Power Hook power frequency magnetic fields should be at levels characteristic of a typical location in a typical professional healthcare environment.
NOTE U_T is the a.c. mains voltage prior to application of the test level.			

7. Appendix

Manufacturer's declaration-electromagnetic immunity			
The United DA Power Hook is intended for use in the electromagnetic environment (for professional healthcare) specified below. The customer or the user of the United DA Power Hook should assure that it is used in such an environment.			
Immunity test	IEC 60601 test level	Compliance level	Electromagnetic environment-guidance (for professional healthcare environment)
Conducted RF IEC 61000-4-6	3 Vrms: 0.15 MHz – 80 MHz 6 Vrms: in ISM bands between 0.15 MHz and 80 MHz	3 Vrms: 0.15 MHz – 80 MHz 6 Vrms: in ISM bands between 0.15 MHz and 80 MHz	Portable and mobile RF communications equipment should be used no closer to any part of the United DA Power Hook including cables, than the recommended separation distance calculated from the equation applicable to the frequency of the transmitter. Recommended separation distance: $d = 1.2 \sqrt{P}$ $d = 1.2 \sqrt{P}$ 80MHz to 800 MHz $d = 2.3 \sqrt{P}$ 800MHz to 2.7 GHz Where <i>P</i> is the maximum output power rating of the transmitter in watts (W) according to the transmitter manufacturer and <i>d</i> is the recommended separation distance in metres (m). Interference may occur in the vicinity of equipment marked with the following symbol: 
Radiated RF IEC 61000-4-3	80 % AM at 1 kHz 3 V/m 80 MHz – 2,7 GHz 80 % AM at 1 kHz	80 % AM at 1 kHz 3 V/m 80 MHz – 2,7 GHz 80 % AM at 1 kHz	
NOTE1 At 80 MHz and 800 MHz, the higher frequency range applies. NOTE2 These guidelines may not apply in all situations. Electromagnetic propagation is affected by absorption and reflection from structures, objects and people.			

7. Appendix

Manufacturer's declaration-electromagnetic immunity Test specifications for ENCLOSURE PORT IMMUNITY to RF wireless communications equipment				
The United DA Power Hook is intended for use in the electromagnetic environment (for professional healthcare) specified below. The customer or the user of the United DA Power Hook should assure that it is used in such an environment.				
Test frequency (MHz)	Band ^{a)} (MHz)	Service ^{a)}	Modulation ^{b)}	IMMUNITY TEST LEVEL (V/m)
385	380 – 390	TETRA 400	Pulse modulation ^{b)} 18 Hz	27
450	430 – 470	GMRS 460, FRS 460	FM ^{c)} ±5 kHz deviation 1 kHz sine	28
710	704 – 787	LTE Band 13, 17	Pulse modulation ^{b)} 217 Hz	9
745				
780				
810	800 – 960	GSM 800/900, TETRA 800, iDEN 820, CDMA 850, LTE Band 5	Pulse modulation ^{b)} 18 Hz	28
870				
930				
1 720	1 700 to 1 990	GSM 1800; CDMA 1900; GSM 1900; DECT; LTE Band 1, 3, 4, 25; UMTS	Pulse modulation ^{b)} 217 Hz	28
1 845				
1 970				
2 450	2 400 to 2 570	Bluetooth, WLAN, 802.11 b/g/n, RFID 2450, LTE Band 7	Pulse modulation ^{b)} 217 Hz	28
5 240	5 100 to 5 800	WLAN 802.11 a/n	Pulse modulation ^{b)} 217 Hz	9
5 550				
5 785				
If necessary to achieve the IMMUNITY TEST LEVEL, the distance between the transmitting antenna and the ME EQUIPMENT or ME SYSTEM may be reduced to 1 m. The 1 m test distance is permitted by IEC 61000-4-3.				
a) For some services, only the uplink frequencies are included. b) The carrier shall be modulated using a 50 % duty cycle square wave signal. c) As an alternative to FM modulation, the carrier may be pulse modulated using a 50 % duty cycle square wave signal at 18 Hz. While it does not represent actual modulation, it would be worst case.				

7. Appendix

Manufacturer's declaration-electromagnetic immunity Test specifications for ENCLOSURE PORT IMMUNITY to proximity magnetic fields		
The United DA Power Hook is intended for use in the electromagnetic environment (for professional healthcare) specified below. The customer or the user of the United DA Power Hook should assure that it is used in such an environment.		
Frequencies	Modulation	Compliance LEVEL (A/m) (for professional healthcare)
30 kHz ^{a)}	CW	8
134,2 kHz	Pulse modulation ^{b)} 2,1 kHz	65 ^{c)}
13,56 MHz	Pulse modulation ^{b)} 50 kHz	7,5 ^{c)}
a) This test is applicable only to ME EQUIPMENT and ME SYSTEMS intended for use in the HOME HEALTHCARE ENVIRONMENT. b) The carrier shall be modulated using a 50 % duty cycle square wave signal. c) r.m.s., before modulation is applied.		

7. Appendix

7.3 Recommended Separation Distances

Recommended separation distance between portable and mobile RF communications equipment and the United DA Power Hook			
The United DA Power Hook is intended for use in an electromagnetic environment (for professional healthcare) in which radiated RF disturbances are controlled. The customer or the user of the DA Power Hook can help prevent electromagnetic interference by maintaining a minimum distance between portable and mobile RF communications equipment (transmitters) and the DA Power Hook as recommended below, according to the maximum output power of the communications equipment.			
Rated maximum output power of transmitter W	Separation distance according to frequency of transmitter m		
	150 kHz to 80 MHz $d = 1.2 \sqrt{P}$	80 MHz to 800 MHz $d = 1.2 \sqrt{P}$	800 MHz to 2,7 GHz $d = 2.3 \sqrt{P}$
0.01	0.12	0.12	0.23
0.1	0.38	0.38	0.73
1	1.2	1.2	2.3
10	3.8	3.8	7.3
100	12	12	23
For transmitters rated at a maximum output power not listed above, the recommended separation distance d in meters (m) can be estimated using the equation applicable to the frequency of the transmitter, where p is the maximum output power rating of the transmitter in watts (W) according to the transmitter manufacturer.			
NOTE1 At 80 MHz and 800 MHz, the separation distance for the higher frequency range applies. NOTE2 These guidelines may not apply in all situations. Electromagnetic propagation is affected by absorption and reflection from structures, objects and people.			

Please note that this Surgical Technique Guide has been authored in the English language. Any translations into other languages have not been reviewed or approved by United Orthopedic Corporation and their accuracy cannot be confirmed. Any translated guide should be reviewed carefully prior to use and questions regarding a Surgical Technique Guide should be directed to United Orthopedic Corporation at unitedorthopedic.com/contact

